

ESTABLISHED 1968

LUMINAIRE CATALOGUE



Rakumba



EN

For more than 50 years Rakumba has been designing and manufacturing luxury lighting. We are proud to be Australia's longest established international lighting brand, bringing heritage, authenticity and technological innovation to the collections and bespoke installations we produce.

As designers and problem solvers, our mission of "making beauty" and our relentless pursuit of perfection pushes us beyond the boundaries of possibility, to explore the creative unknown. Through our collaborations with preeminent Australian and International designers, we bring together contemporary elegance, artisan craft, complex manufacturing and leading edge technology to create iconic lighting with effortless complexity. A legacy of light that is truly exciting.

DE

Seit über 50 Jahren entwirft und fertigt Rakumba dekorative und maßgeschneiderte Leuchten. Wir sind stolz darauf, Australiens älteste internationale Beleuchtungsmarke zu sein, und bringen Tradition, Authentizität und technologische Innovation in die von uns produzierten Kollektionen.

Als Designer und Problemlöser treibt uns unsere Mission "Schönheit zu schaffen" und unser unermüdliches Streben nach Perfektion dazu, die Grenzen des Möglichen zu überschreiten und das kreative Unbekannte zu erkunden. Durch unsere Zusammenarbeit mit Australisch und internationalen Designern bringen wir zeitgenössisches Design, handwerkliches Können, komplexe Fertigung und Spitzentechnologie zusammen, um ausgefeilte Beleuchtungslösungen zu schaffen. Ein Vermächtnis des Lichts, das uns wirklich begeistert.



ARGYLE
PAGE 06



BAILEY
PAGE 14



BALLERINA
PAGE 18



BELL
PAGE 20

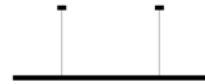

CAPITAL
PAGE 24



PETAL
PAGE 96



PLUME
PAGE 100



PORT
PAGE 104



POTTER DS
PAGE 108



PYLITE
PAGE 112

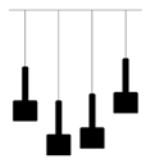

CITY LIGHTS
PAGE 28



ELWOOD
PAGE 32

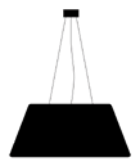

FABRIC LUMINAIRE
PAGE 36

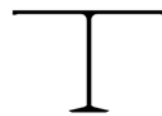

GALLERY
PAGE 40



HANGMAN
PAGE 44



RAMUS
PAGE 116



ROSELLA
PAGE 120



SAYA
PAGE 122

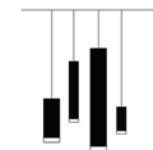

SCOPE
PAGE 128



STANDLEY
PAGE 132



HARU & SO
PAGE 50

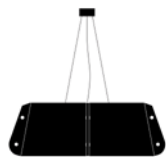

HEKTA
PAGE 54

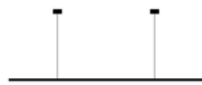

HIGHLINE
PAGE 56



INDRE
PAGE 62



ION
PAGE 70



TULIP
PAGE 136



TYPOGRAPHY CILON
PAGE 138



TYPOGRAPHY VELA
PAGE 148



VOLUTE
PAGE 158

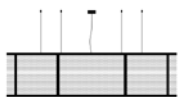

MESH
PAGE 74



METROPOL
PAGE 76



MITO
PAGE 82



MONROE
PAGE 90



PARALLELS
PAGE 92



Design

Nichetto Studio, 2023

Blown glass diamonds weave an intricate fabric of light, through the magic of reflection and tessellation.

Inspired by Australia's famed coloured diamonds and the Argyle textile pattern, Nichetto Studio has thoughtfully combined Luca Nichetto's native legacy of contemporary glass design with Rakumba's half-century heritage of lighting and fabric.

Interpreted through the medium of glass, the Argyle collection reveals interlocking diamond forms, composed in colourless or subtly coloured layers. Presenting as pendant, floor and table lamps, Argyle spans a multitude of applications; singular gem-like units hanging above tables, tessellating screens forming a tapestry of light across open spaces, and grand chandelier compositions in luxurious foyers. Nichetto Studio's collaboration with Rakumba represents their first work with an Australian brand and reflects a shared love of strong narrative and emotional connection to design.

Argyle: Weaving light into diamonds.



Model

Pendant
Table lamp
Floor lamp

Finish - Glass

Sunset
Sunrise
Forest
Dusk
Colourless

Finish - Metalwork

Golden anodised
Black anodised

>

Argyle Pendant | Sunrise



Argyle Pendant & Floor | Colourless
v

Argyle Pendant & Floor | Sunset
>



NOTE

REMOVABLE OUTER GLASS LAYER
ALWAYS SUPPLIED

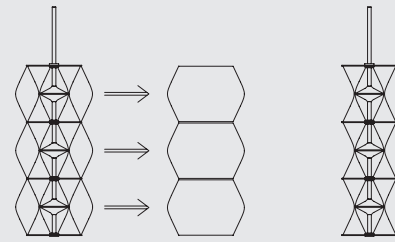

PENDANT

Ø300 X H215, 430, 645 ... 1720 MM
MAXIMUM OF 8 LIGHT MODULES

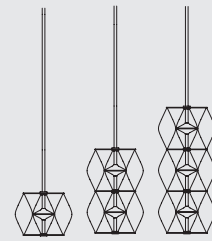
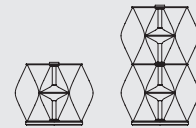

TABLE LAMP

Ø300 X H225, 440 MM
MAXIMUM OF 2 LIGHT MODULES



FLOOR LAMP

Ø350 X H1300 MM
MAXIMUM OF 6 LIGHT MODULES



Argyle Pendant | Colourless



Argyle Pendant | Colourless



SEE FULL CONFIGURATIONS



Design

Tom Fereday, 2017

Bailey distils centuries of glass working mastery into a captivating modern form. Using ancient Italian optic glassblowing techniques, Bailey pushes the intricate process into new territories, superimposing vertical flutes onto a softened diamond at a dramatic and challenging scale. To accomplish this, each Bailey pendant is carefully handcrafted by famed Australian glass artist, Tom Rowney.

Beyond beautiful single pendants, Bailey's tessellating form nests in multiples to build intriguing compositions, taking advantage of positive and negative space. A range of rich glass colours are offered to complement your design palette.



Dimensions

Ø240 x H450 MM

Finish - Glass

Steel blue
Steel green
Whisky
Frost

Finish - Metalwork

Brass
Black



Bailey Pendant | Steel Blue
<

Bailey Pendant | Whisky
v





Design

Simone LeAmon, 2011

An extravagant statement of Edwardian proportions, Ballerina is defined by its silhouette of twists and frills. Crafted with couture-level detailing and intricate handcrafting, Ballerina is an elegant nod to a time when the advent of electricity led to a revolution in design and manufacturing.

Endowing Ballerina with contemporary elegance is a gracefully formed tripod stand shoed in solid copper, and integrated LED lighting producing a brightly glowing spotlight worthy of the name.



Model

Prima
Petit

Dimensions

Prima - Ø1450 x H2000 MM
Petit - Ø650 x H1800 MM

Finish

Black satin



Design

AFTR, 2023

The Bell collection by AFTR studio is defined by its clarity of form. An artfully reduced geometry with an emphasis on scale and proportion, Bell quietly enhances architecture while contributing a raw monolithic materiality.

With each piece uniquely textured from the sculpturally inspired sand casting process, Bell features naturally ageing raw aluminium or bronze and also comes in contemporary powdercoat finishes. Capable of seamlessly transitioning from indoor to outdoor spaces, Bell is available in weather sealed models at two harmonious scales.



Model

Classic
Large

Dimensions

Classic - 75 X 175 X H130 MM
Large - 100 X 225 X H170 MM

Finish

Cast bronze
Cast aluminium
Black powdercoat
White powdercoat



Bell Classic | Cast Bronze



Bell Large | Cast Aluminium





Design

Archier, 2016

An elegant linear pendant with presence, Capital is a contemporary nod to Art Deco New York style. Carefully considered fluted brass and solid timber detailing builds visual impact, drawing the eye and bringing fine texture to beautiful spaces.

Featuring waxed brass living finishes that age gracefully and patina over time, this pendant series is simultaneously luxurious and deeply functional; the independently controlled up and down illumination offers significant scope for sophisticated lighting schemes.

White or black editions are available for a monochromatic aesthetic.



Dimensions

30 X 45 X L1400 MM
30 X 45 X L1800 MM
30 X 45 X L2400 MM

Finish - Profile

Satin brass
Patina brass
Black powdercoat
White powdercoat

Finish - Detail

Walnut
Black
White

Capital Pendant | Patina Brass



Capital Pendant | Satin Brass





CITY LIGHTS

RP-E-1512

29

Design

2015

Contemporary glamour is tempered by the minimalist simplicity of City Lights. Pared back design marries elongated lines and pure geometric form, creating a light evoking Melbourne's eclectic and sophisticated style.

City Lights can be used solo in intimate spaces, or curated into a cluster of uniform or varying heights. Expand City Lights into an impressive chandelier as the design focus for a grand dining area or reception hall.



Dimensions

Ø60 X H138 MM

Finish

Polished brass
Tumbled brass
Patina brass
Black anodised
White powdercoat
Custom



City Lights Pendant | Polished Brass

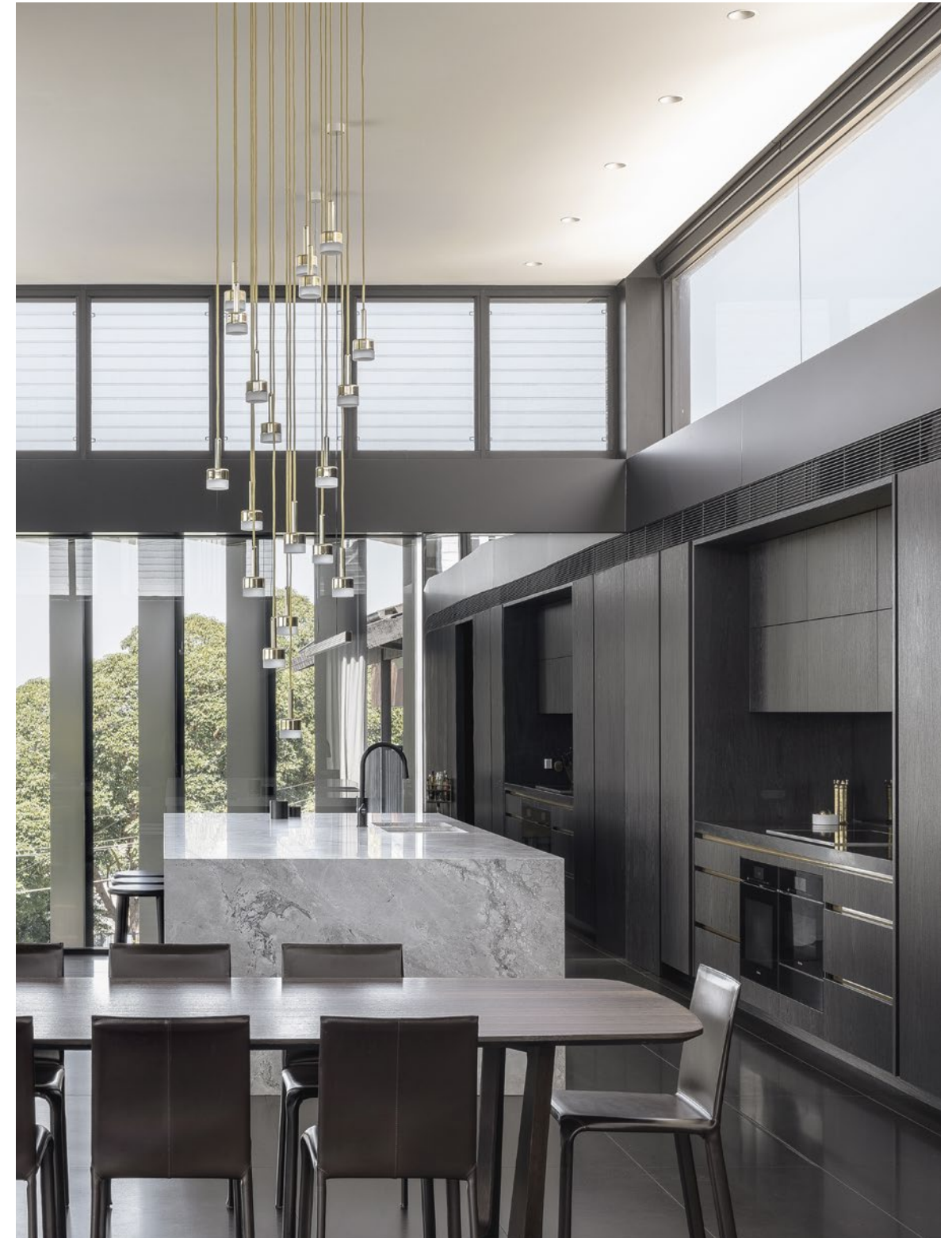



Design

2023

The Elwood collection comprises quintessential elements of classically timeless wall lighting. A study in proportion, Elwood floats an elegantly formed shade over a crisp backing plate – the subtly offset proportions bringing stylistic rigour to this framing detail.

Myriad finishes bring sophisticated luxury to the clean form, with indoor editions featuring customisable, richly textured fabrics over hand finished brass or powdercoated plates. Stepping outdoors, weather sealed models feature solid metal construction in both brass and powdercoated steel. For versatility, Elwood is available in portrait and larger landscape oriented variants.



Model	Portrait indoor Portrait outdoor	Landscape indoor Landscape outdoor
Finish - Shade	Fabric (customisable) Powdercoat (matching backplate)	Satin brass Patina brass
Finish - Backplate	Black powdercoat White powdercoat Bronze powdercoat	Custom powdercoat Satin brass Patina brass

PORTRAIT INDOOR

240 X 70 X H340 MM

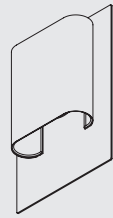

LANDSCAPE INDOOR

320 X 70 X H340 MM

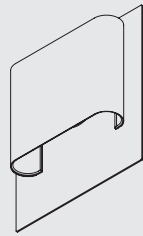

PORTRAIT OUTDOOR

240 X 70 X H340 MM

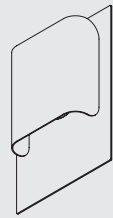

LANDSCAPE OUTDOOR

320 X 70 X H340 MM

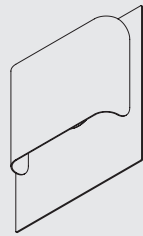

Elwood Landscape Outdoor | Bronze Powdercoat

Elwood Landscape Indoor | Black Powdercoat



Design

Rakumba

Rakumba's Fabric Luminaires are one of the most expressive design tools in your creative cache of lighting. They can bring glamour and distinction to a space, or sensitively blend into their surrounds.

The versatility of Fabric Luminaires allows them to feature in almost any interior. From home to hospitality spaces, and commercial interiors including workplace, retirement living, health, education, civic and more.

Rakumba's Fabric Luminaire collection encompasses a variety of archetypal forms, giving you the freedom to create lights that reflect your design language. Browse our fabric selection or specify your own textile, wallpaper or other finishes.



Model

- | | |
|---------------------|-----------|
| Canterbury | Loft |
| Cirque | Metro |
| City Hall | Quad |
| Geometry 8 | Ratio |
| Introvert/Extrovert | Stadium |
| Iris | Tesselate |
| Kis | |

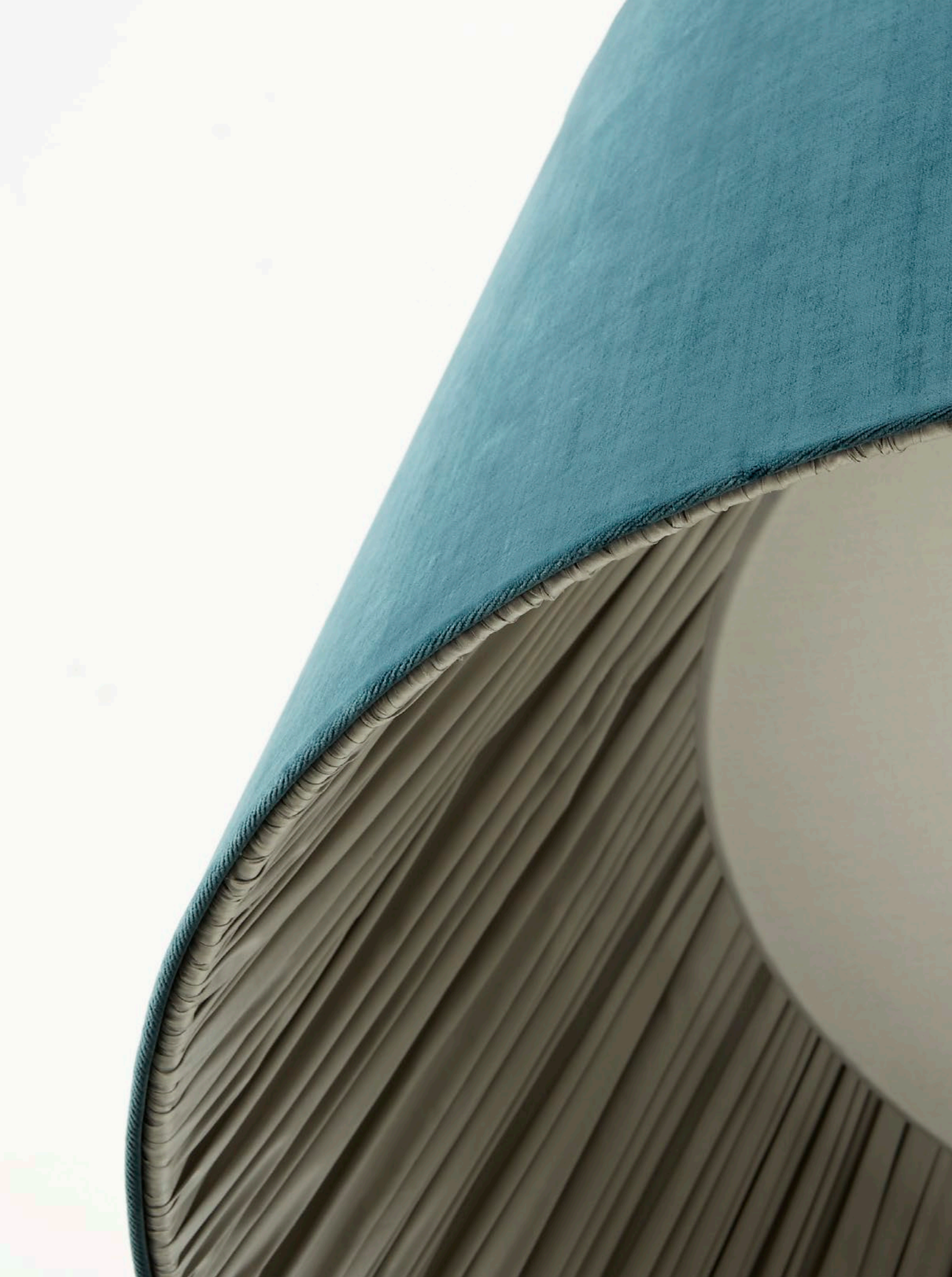

Canterbury

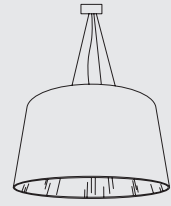

Loft

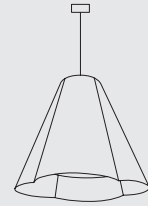

Cirque

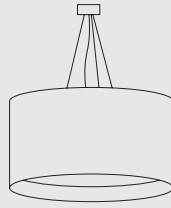

Metro

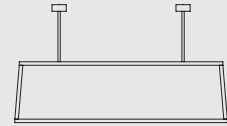

City Hall

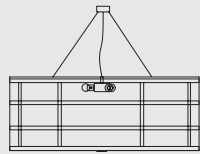

Quad

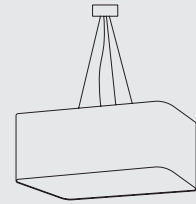

Geometry 8

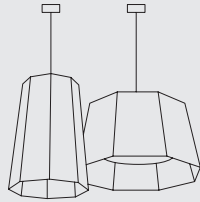

Ratio

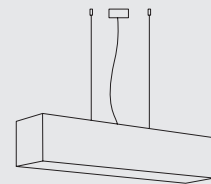

Introvert/Extrovert

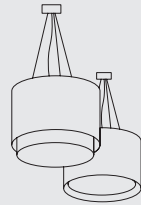

Stadium

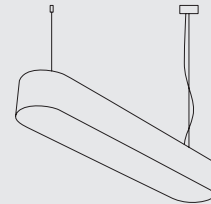

Iris

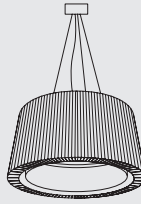

Tessellate

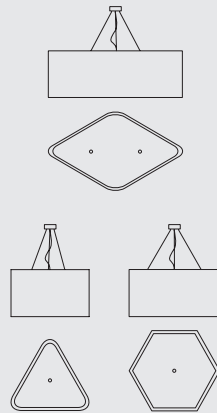

Kis

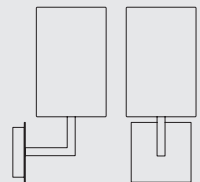

Fabric Luminaire Model



Fabric Luminaire | Cirque





Design

Tom Fereday, 2023

The Gallery collection presents a selection of highly desirable archetypal lighting forms with exquisitely detailed minimalism, luxurious materiality and subtle articulation.

An extension to his commissioned pieces for the Art Gallery New South Wales, designer Tom Fereday's sculptural training and ethos of honest materiality are apparent in the enduring solidity of hand-finished brass. Within each luminaire, performance illumination is coupled with artfully concealed directional adjustment – delivering effortlessly pure forms with unexpectedly versatility.

Comprising classic styles including a bankers lamp, architects lamp, wall, bedside and a distinctly contemporary modular linear pendant system, Gallery brings a meticulous new perspective to timeless lighting.



Model

Bankers lamp
Architects lamp
Wall
Bedside
Pendant

Finish

Tumbled brass
Patina brass
Black powdercoat
Custom plated

ARCHITECTS LAMP
ARCHITECTS LAMP INTEGRATED

520 X 140 X H360 MM
520 X 80 X H360-460 MM

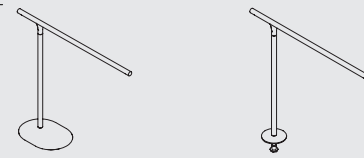

BANKERS LAMP 340
BANKERS LAMP 340 INTEGRATED

340 X 145 X H360 MM
340 X 80 X H360-460 MM

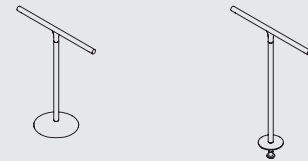

BANKERS LAMP 540
BANKERS LAMP 540 INTEGRATED

540 X 145 X H360 MM
540 X 80 X H360-460 MM

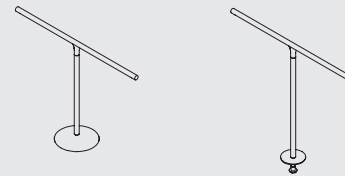

PENDANT 900
PENDANT 1800
PENDANT 2600
PENDANT 3500

Ø16 X L910 MM
Ø16 X L1765 MM
Ø16 X L2620 MM
Ø16 X L3475 MM

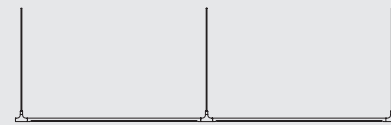

BEDSIDE

80 X 65 X H150 MM

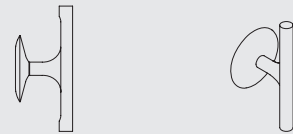

WALL 340
WALL 540

80 X 65 X H340 MM
80 X 65 X H540 MM

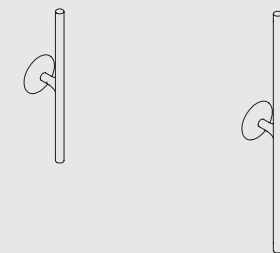

Gallery | Bankers Lamp



Gallery | Bankers Lamp Integrated

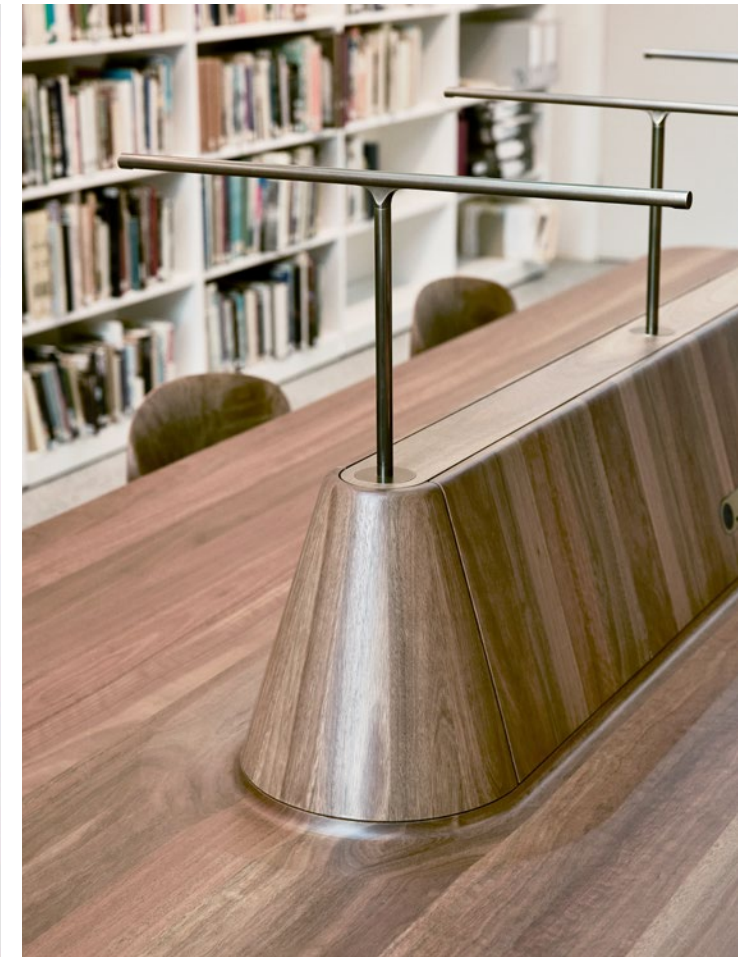
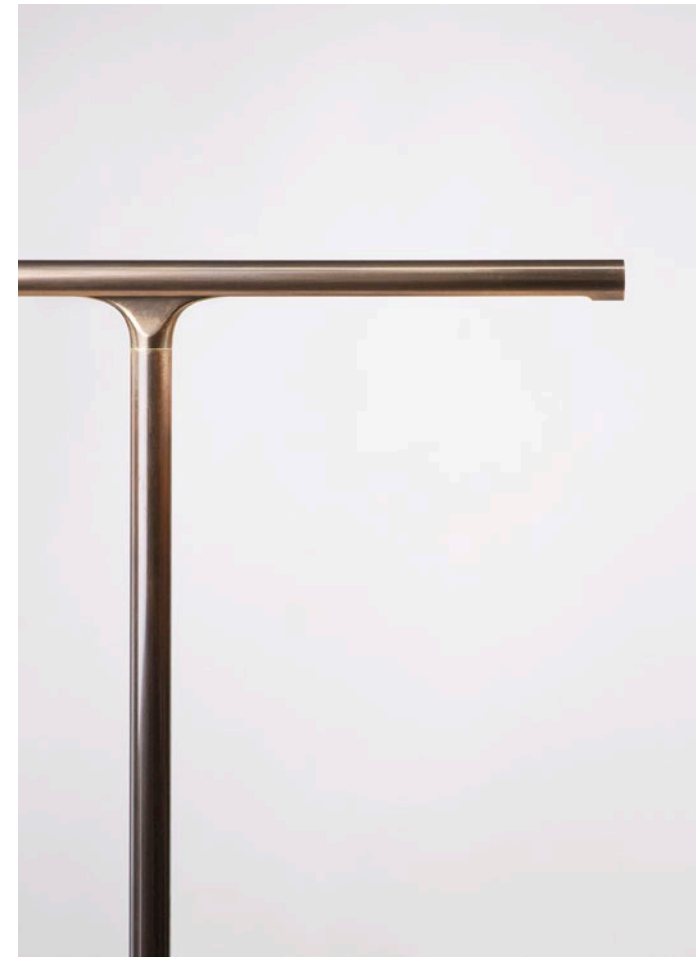



HANGMAN

RP-E-2105

45

Design

Adam Goodrum, 2021

An iconic piece filled with character and nostalgia, Hangman takes its inspiration from the universally renowned analogue game of 'Hangman'.

The light is an exercise in playful design and simple, yet magically executed geometry. Featuring multiple articulated joints, you can manipulate Hangman's arm sections into a variety of positions to create the illumination and graphic aesthetic desired. At the end of each arm is a meticulously designed light source which appears as a polished, glowing tip.

The Hangman series is available as a characterful table and floor lamp, or a dual tipped ceiling pendant capable of myriad configurations. Choose from two distinctive finishes - the classic universality of anodised black, or the glamour of raw polished aluminium designed to elegantly age over time.



Model

Floor lamp
Table lamp
Pendant

Finish

Black anodised
Polished aluminium

Hangman Floor Lamp | Polished Aluminium

Hangman Pendant | Polished Aluminium
Hangman Pendant | Black Anodised
Hangman Floor Lamp | Polished Aluminium



FLOOR LAMP

Ø590 X H1510-1900 MM



TABLE LAMP

Ø365 X H475-770 MM

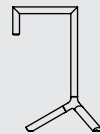

PENDANT
Primary Orientation 1

36 X 105 X L725 MM

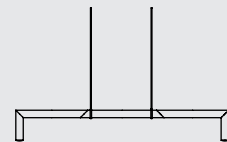

PENDANT
Primary Orientation 2

36 X 325 X L285 MM

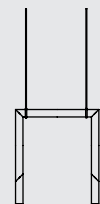

Hangman Model
<

Hangman Table Lamp | Black Anodised
v

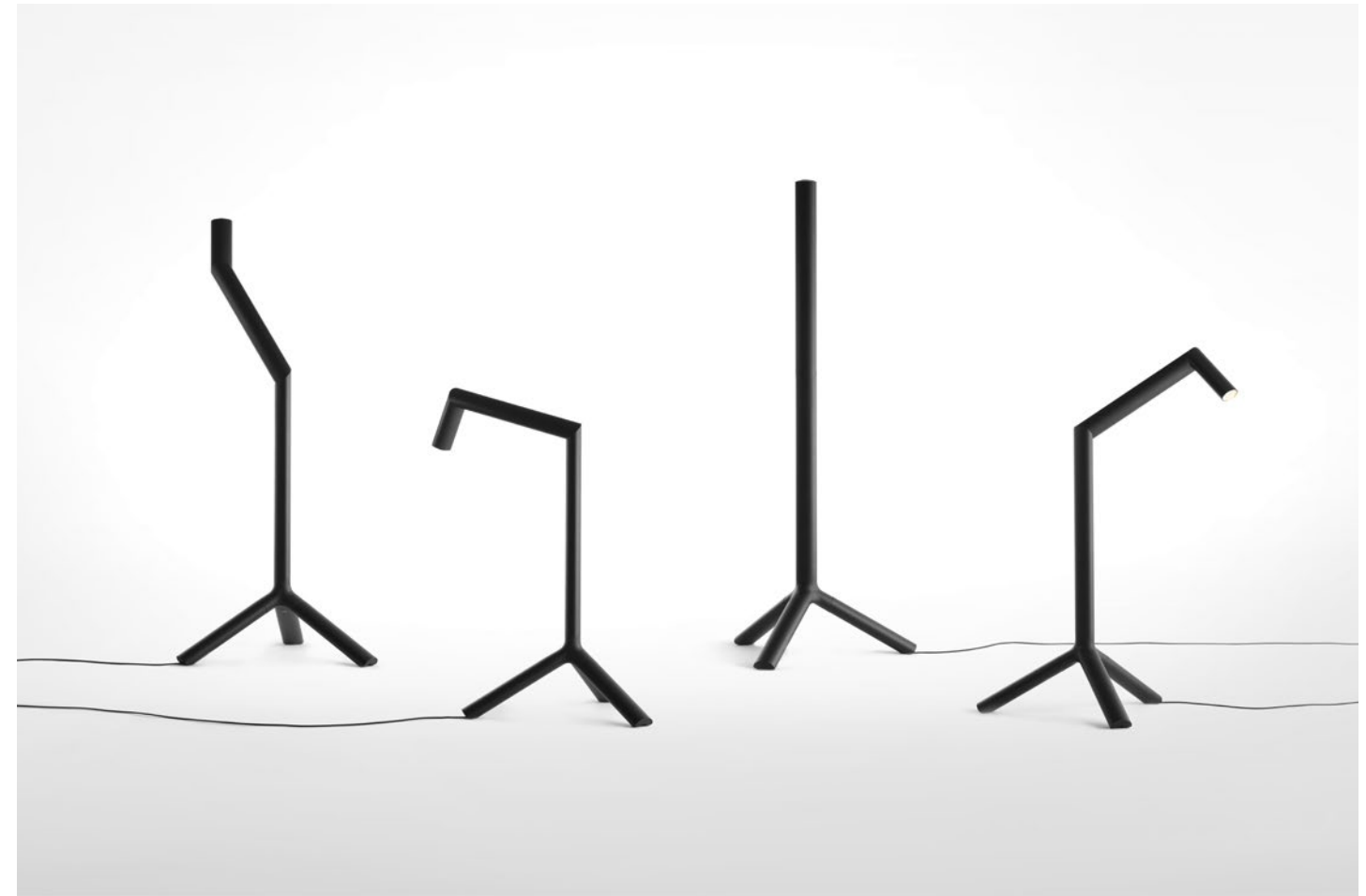



Design

Tom Skeeahan, 2023

An intrinsically linked pair, the Haru and So table lamps by Australian designer Tom Skeeahan are a celebration of material-driven design, blending centuries-old artisan techniques with contemporary form and colour theory.

Each Haru and So lamp is individually hand-blown by Australian glass artists, with form and scale challenging the boundaries of traditional glassworking. Recurring curved motifs and a shared anthropomorphic aesthetic across Haru and So creates a visually striking, complementary pair, enhanced by the captivating depths of layered colour.

Haru and So provide the perfect blend of tradition and modernity, craftsmanship and creativity, creating sculptural moments in sophisticated interiors.



Model

Haru
So

Finish

Blue
Teal
Amber

HARU

Ø250 X H310 MM

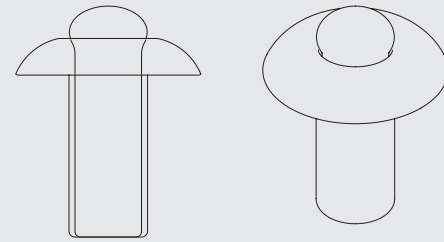

SO

Ø200 X H215 MM

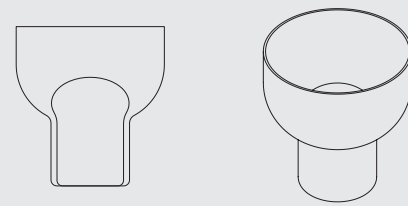

Haru & So Model

Haru & So | Blue and Amber

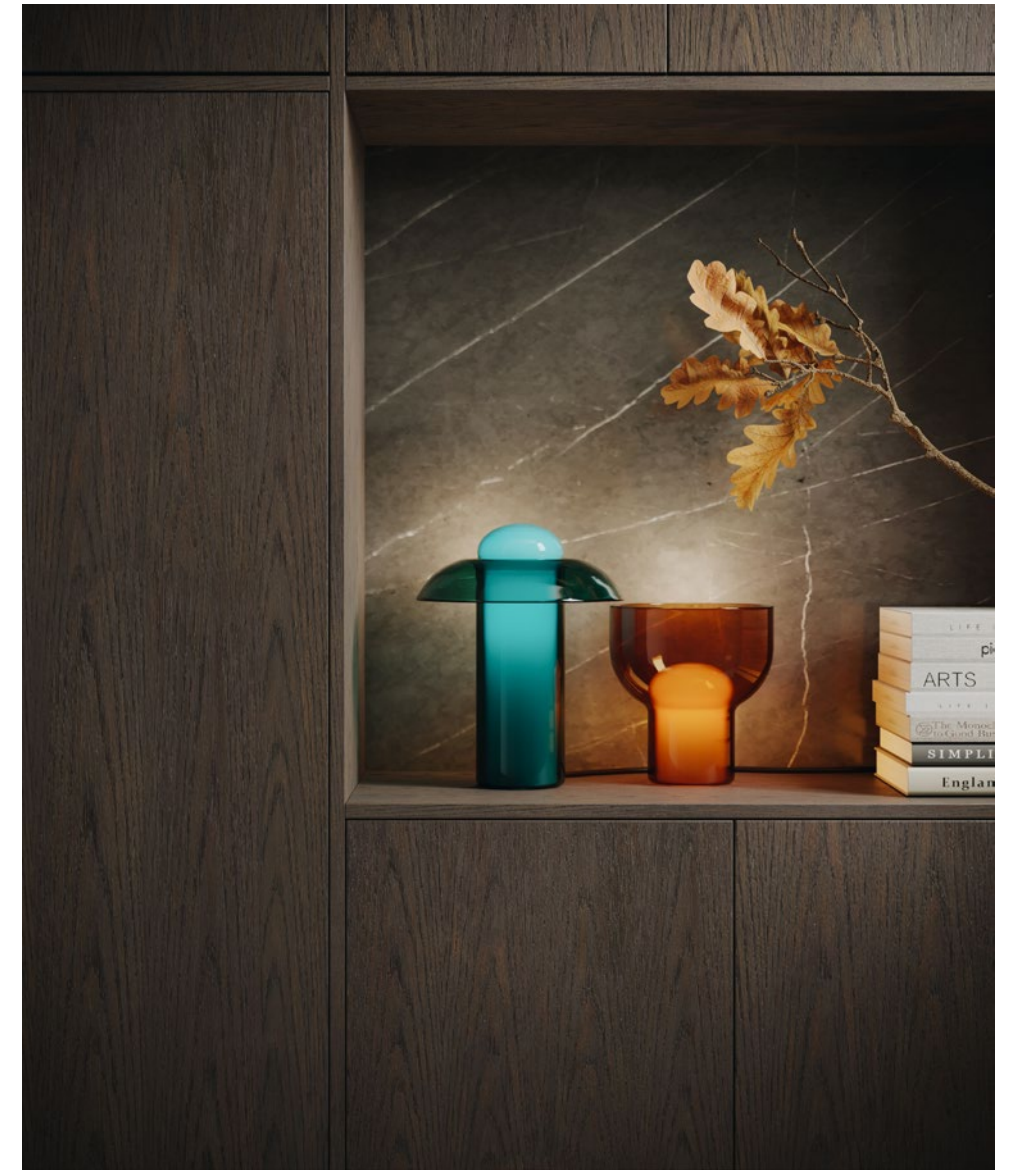



Design

Alex O'Connell, 2015

A comment on sustainable and function driven design, Hekta is crafted from acoustic felt made from recycled PET bottles. Each aspect of Hekta is carefully considered including colour matched inset acrylic detailing.

The range offers superior illumination with integrated LED and clever acoustic benefits through the combination of performance material and sound dispersing form. Ideal for commercial, educational, and residential applications.



Dimensions

Ø600 x H280 MM
Ø800 x H360 MM

Finish - Primary

Nimbus
Charcoal
Glacier

Finish - Fin Detail

Black	Green
White	Blue
Yellow	Orange

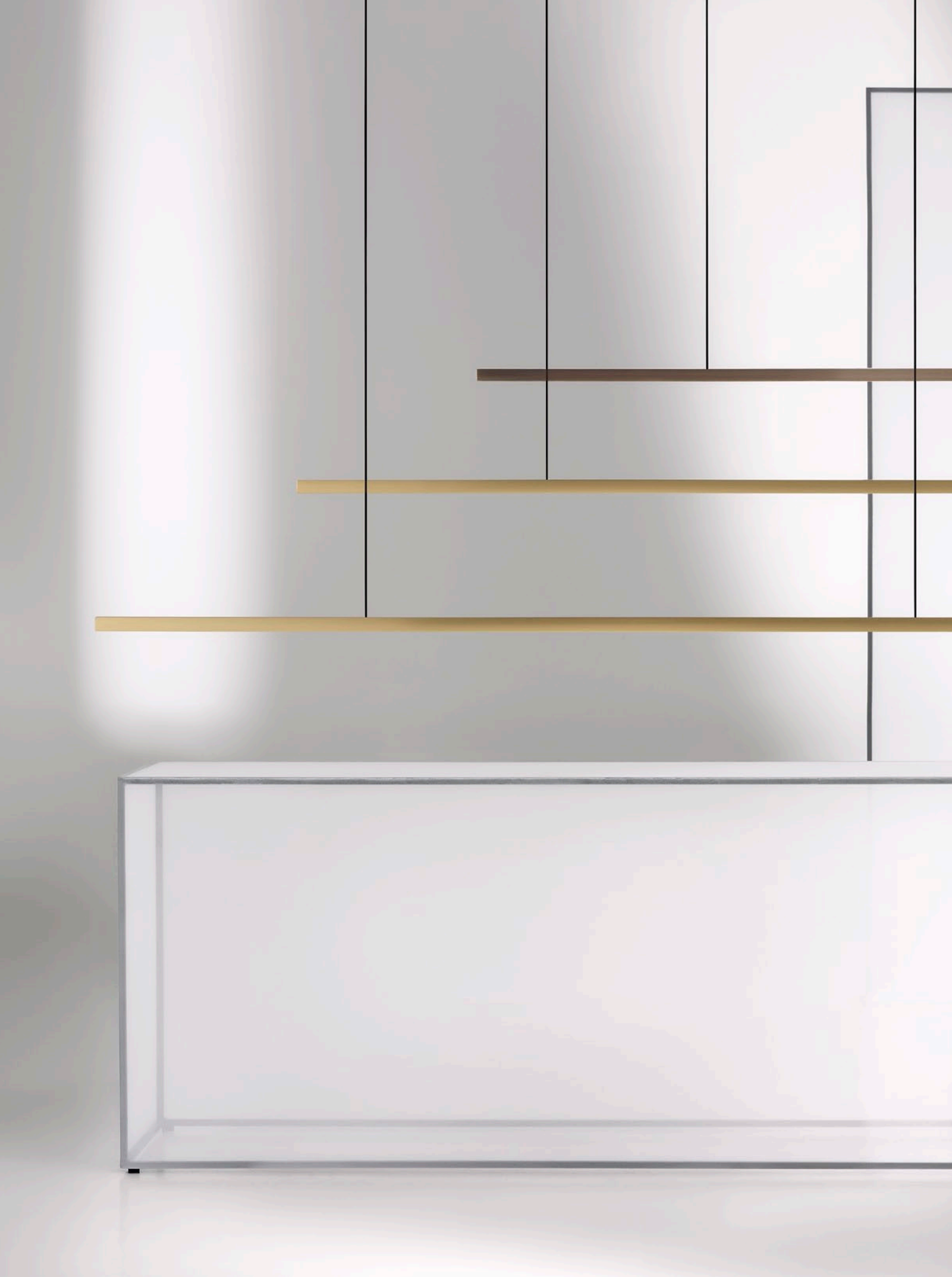

HIGHLINE

RP-E-1502P

57

Design

Archier, 2015

Minimalist and elegant, Highline is a true modern classic of linear lighting, prized for a sense of restrained luxury that allows the surrounding architecture to shine. With carefully considered detailing, Highline showcases honest, precious materiality and exemplary craftsmanship.

Despite the slim profile, Highline incorporates both upward and downward lighting of impressive potency. The luminaire features oiled walnut details and waxed brass living finishes that age gracefully and patina over time. White or black editions are available for a monochromatic aesthetic.



Dimensions

20 X 24 X L1400 MM
20 X 24 X L1800 MM
20 X 24 X L2400 MM

Finish - Profile

Satin brass
Patina brass
Black powdercoat
White powdercoat

Finish - Detail

Walnut
Black
White



Highline Pendant | Satin Brass
< ▾



Highline Pendant | Black Powdercoat



Highline Pendant | Satin Brass





Design

Nikolai Kotlarczyk, 2020

INDRE elegantly conjures the suspended catenary streetlights and cobbled stone streets of Copenhagen. Delicately rendered double-wall glass capsules cradle the soft glow of floating internal lights, each connected by graceful interlinking rods and anchored with rich stone or timber detailing.

INDRE's intelligent modularity ranges from refined singular pendants, wall sconces and table lamps, to elegant compositions for reception, dining or bar settings, and spectacular chandeliers for grand spaces.



Model

Pendant
Wall
Table lamp

Finish - Metalwork

Gunmetal White
Golden Custom

Finish - Anchor

Forest green marble Carrara
Classic light travertine Oak
Nero marquina



Indre Pendants | Configuration A1, A2, A3
<

Indre Table Lamp | Classic Light Travertine
v



Indre Pendant | Configuration A2 & A1
v

Indre Wall | Forest Green Marble
>

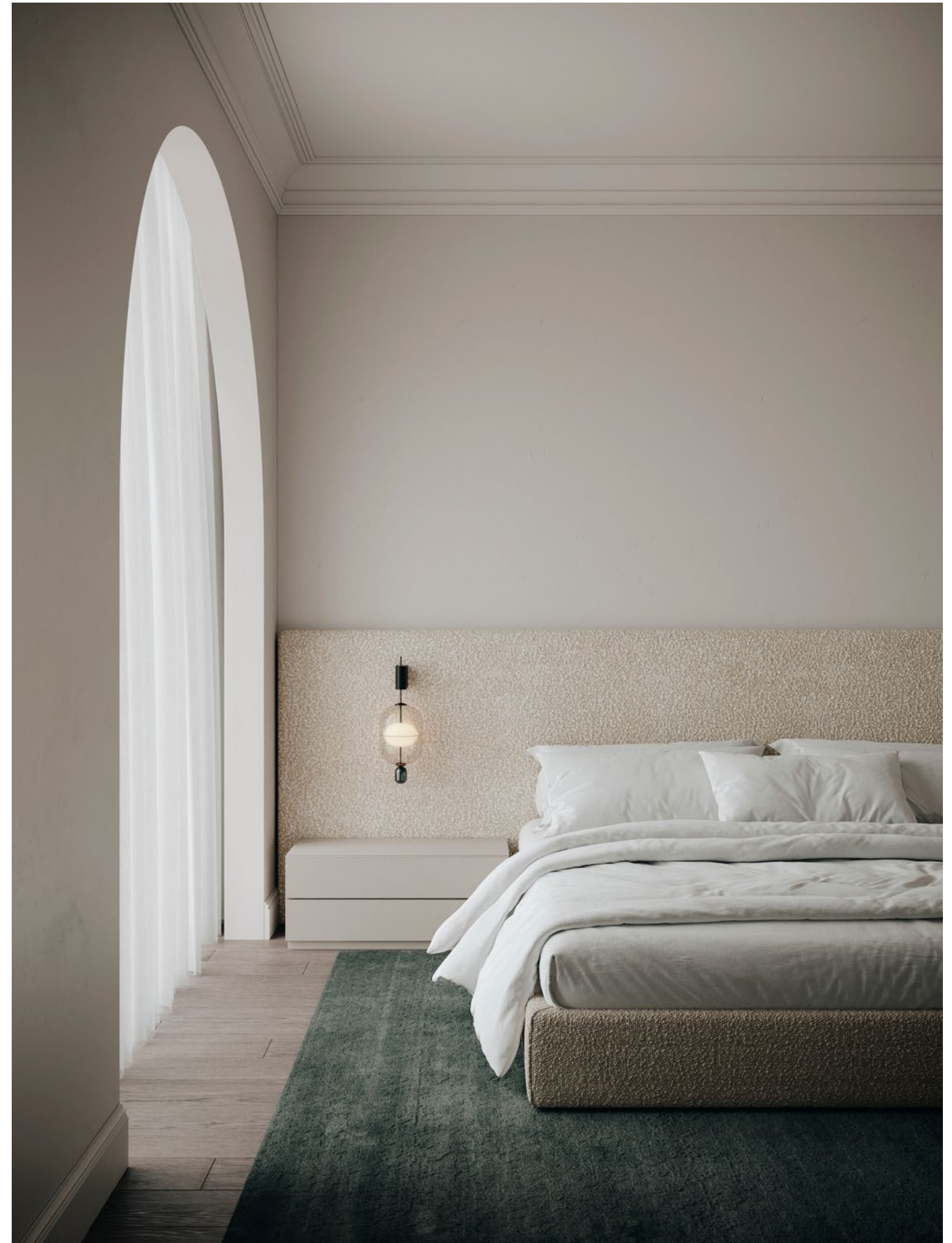

3D CHANDELIER
Configuration J 870 X 870 X H1013 MM

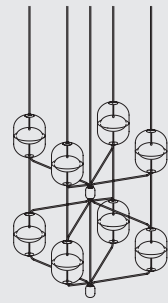

LINEAR CHANDELIER
Configuration C2 170 X 1570 X H1013 MM

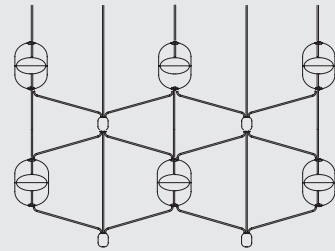

PENDANT
Configuration A1, A2, A3 Ø170 X H315, 600, 885 MM



WALL
Configuration W1, W2, W3 210 X 170 X H505, 790, 1075 MM

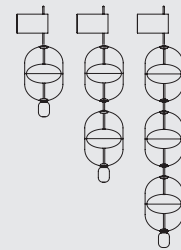

TABLE
Ø170 X H385 MM



Indre Model
<

Indre Chandelier | Configuration L
v



SEE FULL CONFIGURATIONS



Design

2023

Drawing inspiration from the Ionic discipline of ancient Greek architecture, Ion examines classic architectural design cues and alloys them into a contemporary and sophisticated outdoor lantern collection. Ion's signature glass colonnade hints at the appeal of fluted glass, whilst being distinctly unique.

Once illuminated, Ion reveals new structural elements as warm, ambient lighting filters and refracts through the tubes cascading to the base. An ability to interchange these glass tubes with solid columns allows for an exceptional level of control over lighting directionality. With two scales tailoring to different applications, Ion presents a refined and versatile design choice for fixed mount architectural lanterns.



Model

Floor Classic
Floor Tall
Pendant Classic
Pendant Tall

Dimensions

Classic - Ø300 X H450 MM
Tall - Ø300 X H600 MM

Finish

Medium bronze powdercoat
Textured black powdercoat
Textured white powdercoat



ION | Tall



ION | Details



ION | Classic



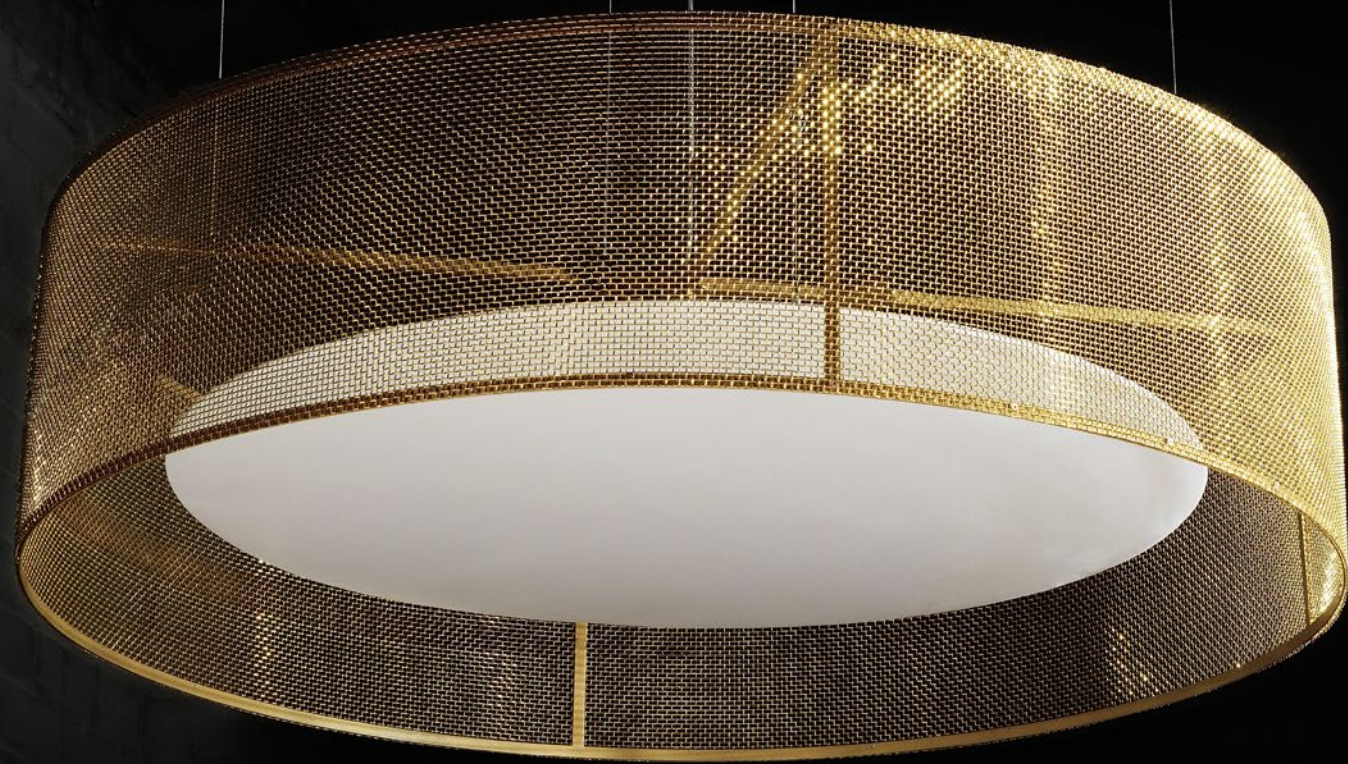

Design

2014

A metallic presence with the lightness of transparency. The Mesh series exudes raw luxe decadence in glimmering polished brass, or takes an industrial chic aesthetic with optional powdercoat finishes.

Perfect in commercial and hospitality interiors, Mesh is customisable in size and finish.



Dimensions

Ø300-1500 x H400 MM
Custom

Finish

Polished brass (spiral woven)
Polished brass (flat woven)
Powdercoat (perforated)
Powdercoat (flat woven)



Design

Sebastian Herkner, 2020

Like a pearl hanging from a thread, Metropol exudes a quiet charisma. Its design is one of intricacy and sophistication, delivering distinctive beauty while also leaving room for surrounding architecture to speak.

Central to Metropol's design is the finely seamed trifoliate form, emitting a warm and soft cast of light through precise glass columns. The luminaire is presented singularly as a sconce or pendant, and extends to stacked double and triple pendant editions - elegant as solo statement pieces, or curated into organic groupings and grand chandeliers.



Model

Pendant
Wall

Size

Small
Large

Finish - Metalwork

Black anodised
Golden anodised

Finish - Glass

Frosted white
Frosted pink

Metropol Wall | Frosted White & Golden Anodised

Metropol Pendant | Frosted White & Black Anodised



PENDANT SMALL

Ø100 X H380 MM
Ø100 X H720 MM
Ø100 X H1065 MM

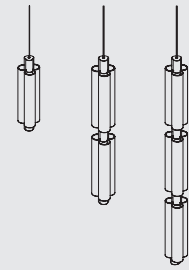

PENDANT LARGE

Ø120 X H460 MM
Ø120 X H885 MM
Ø120 X H1310 MM

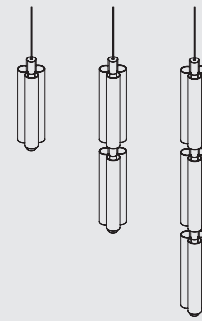

WALL SMALL

100 X 80 X H360 MM



WALL LARGE

120 X 90 X H440 MM



Metropol Model
<

Metropol Chandelier | Frosted Pink & Golden Anodised
v

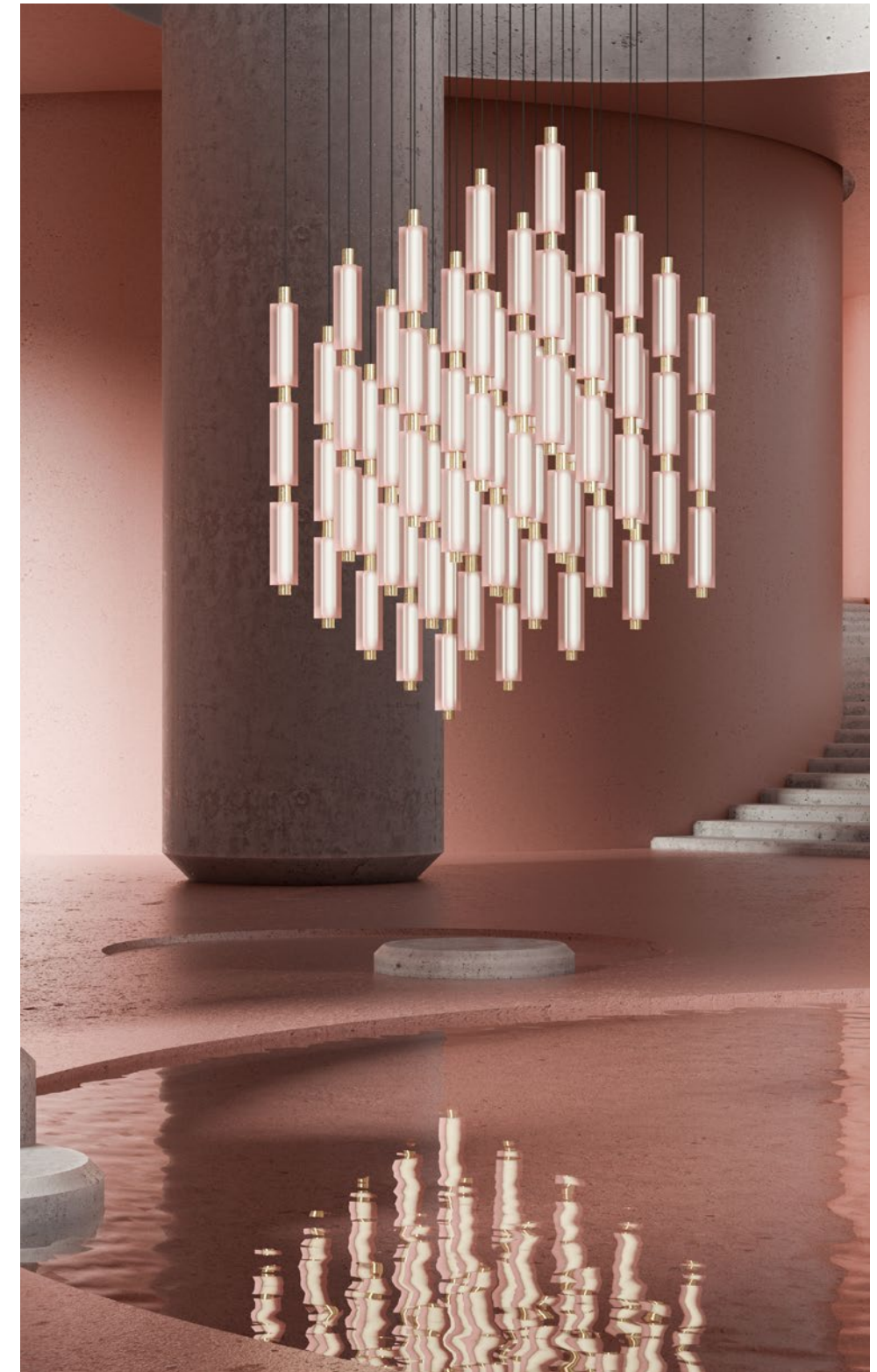



 Design

Tom Fereday, 2017

A study in honest materiality, Mito celebrates the natural beauty of raw materials through a series of minimal forms composed into a sculptural luminaire. Mito employs precision craftsmanship to draw out the most beautiful facets of its timber and stone foundation.

With each component existing as an independently precious object, the distinctive stem motif threads these figures into a cohesive whole. Expressed in pendant, wall, floor and table lamp configurations.



 Model

Floor lamp
Table lamp
Wall
Pendant

Finish

Carrara marble
American ash
Stained american ash

MITO
Mito Wall | Carrara Marble



MITO
Mito Floor & Table | Stained American Ash



MITO
Mito Floor | Carrara Marble



MITO
Mito Floor | American Ash



MITO
Mito Floor | American Ash



FLOOR LAMP

350 X 250 X H1700 MM



TABLE LAMP

350 X 200 X H520 MM

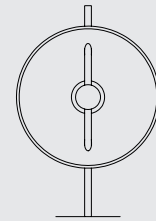

WALL

350 X 65 X H500, 950, 1400 MM



PENDANT

350 X 60 X H500-2000 MM



Mito Model
<

Mito Floor | Carrara Marble
v





Design

WOWOWA, 2014

A geometric statement of shadow and light, Monroe is a shining example of texture, material and form working in finely balanced harmony. Fascinating as a single feature, or in multiples as a grand contemporary chandelier.

Cast from solid brass, Monroe is available in a high-polished 'Glamour' finish, or opt for the intriguingly textured etched surface of 'Rough Night'. Also available in powdercoat colours to suit a broad variety of projects.



Dimensions

Ø250 x H190 MM

Finish - Glass

Glamour
Rough night
Black powdercoat
White powdercoat
Custom powdercoat



Design

2021

An elegant elliptical profile of carefully refined proportions, Parallels pares back all unnecessary detail. Uncompromising in its minimalism, the oval form shifts in silhouette when viewed from various angles, engaging the gaze. This subtle shift brings new life and contrast to each compositional arrangement.

Parallels' design language speaks softly, allowing the considered detailing and curated finishes to complement architecturally designed spaces. Length and finish can be customised for a bespoke statement, with optional upward illumination bringing significant lighting design potential.



Model

Pendant
Wall

Dimensions

50 X 30 X H400 MM
50 X 30 X H700 MM
50 X 30 X H custom

Finish

Black anodised
White powdercoat
Bronze powdercoat
Custom

Illumination

Down lighting
Up & Down lighting



Parallels Pendant | Black Anodised
< v



Parallels Wall | Bronze Powdercoat
v

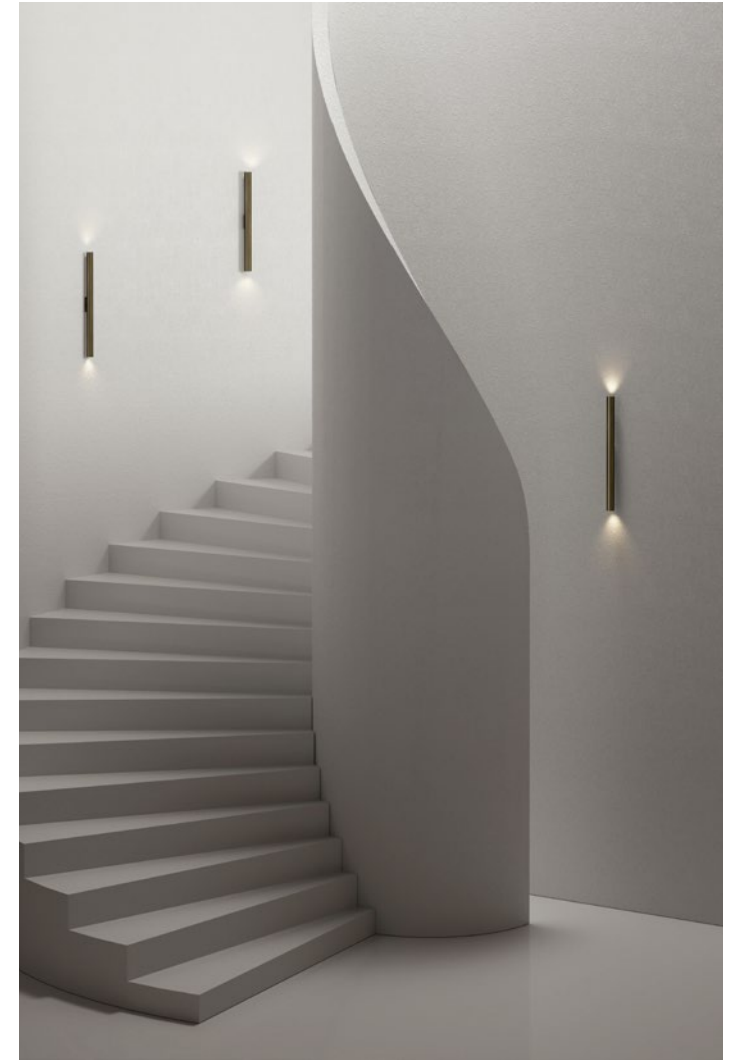



Design

Sebastian Herkner, 2023

Capturing a mutual passion for botanical beauty, the Petal collection reflects Sebastian Herkner's ongoing creative dialogue with Rakumba. Petal draws inspiration from the texture, form and colour of flowers within Sebastian's own home.

Herkner represents the delicacy of floral structure through a hand drawn radiating texture on the glass surface, splaying outwards from a gently curved, glowing light. The light source is embraced within two asymmetric 'petals', refracting a subtle spectrum of highlights and shadows. This unique form is presented as a pendant and wall sconce in two scales, with an alluring table lamp edition completing the series.



Model

Pendant classic
Pendant large
Wall classic
Wall large
Table lamp

Finish - Metalwork

Golden anodised
Black anodised

Finish - Glass

Colourless
Bronze
Custom

PENDANT CLASSIC 180 X 100 X H235 MM
PENDANT LARGE 220 X 100 X H285 MM

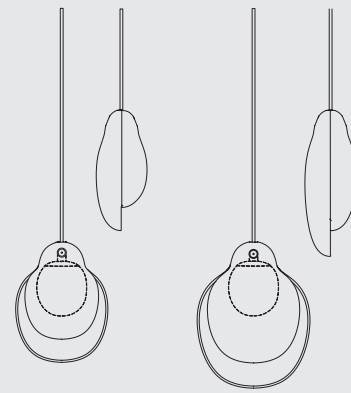

WALL CLASSIC 180 X 130 X H235 MM
WALL LARGE 220 X 130 X H285 MM

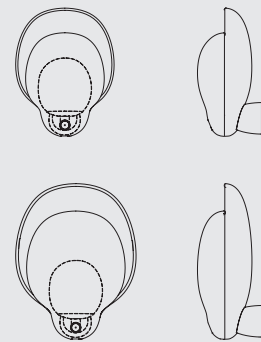
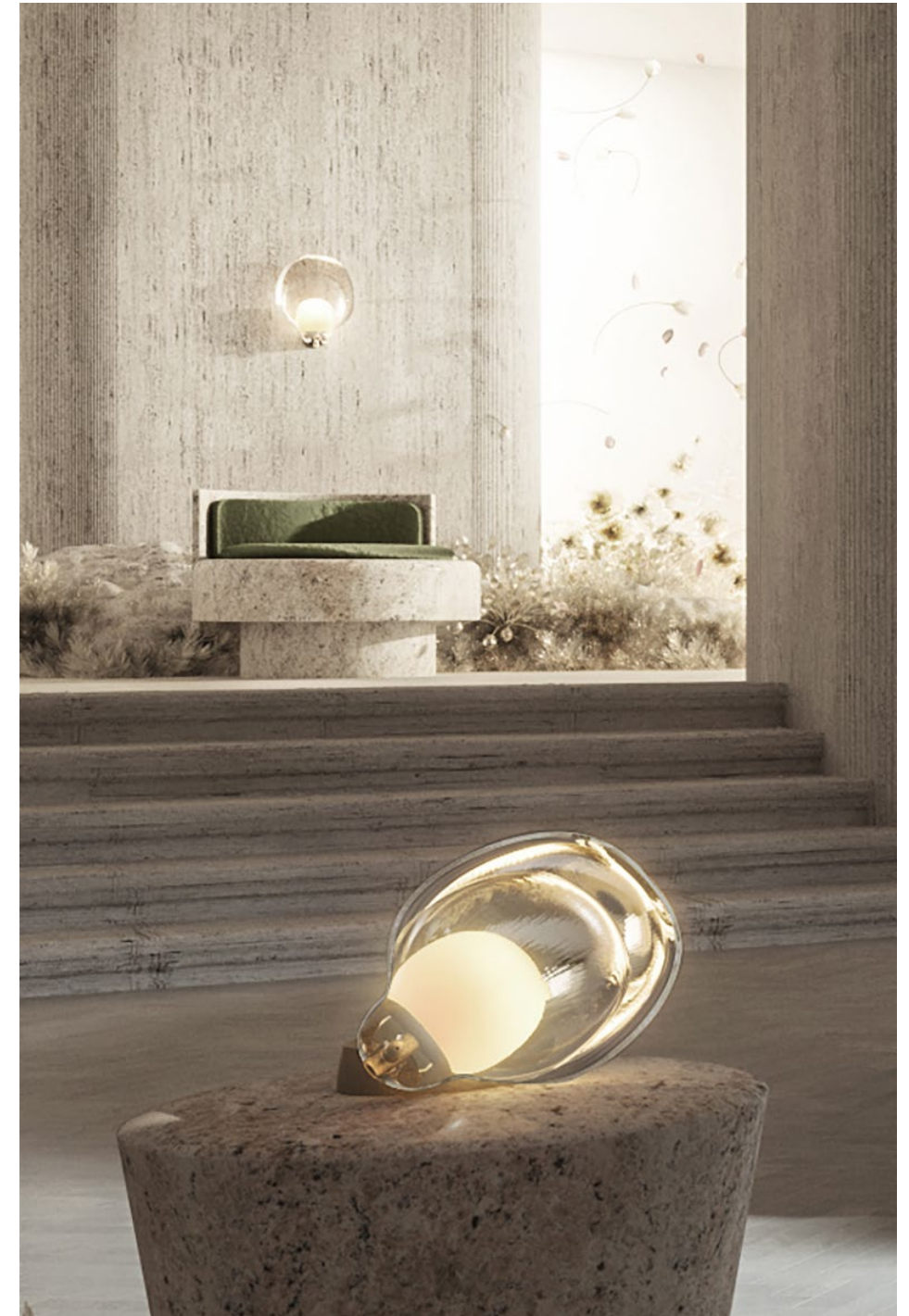
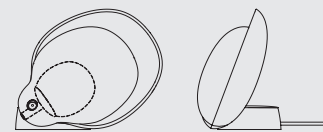

TABLE LAMP 270 X 170 X H230 MM



Design

Tom Skeeahan, 2023

PLUME is grounded in a love of materials research and acclaimed Australian designer Tom Skeeahan's transparency of experimentation.

Controlling the distortion of sheet aluminium by forming selective regions, Skeeahan manipulates the ductile medium into a graceful three-dimensional form. Beyond material and appearance, Plume pays tribute to Tom's mentorship from the late Robert Foster with vibrant hues expertly applied by Foster's iconic FINK + Co. anodising team.

Through shared joy in discovery, PLUME represents the relationship between light, colour and nothing being ordinary.



Dimensions

220 X 105 X H360MM

Finish

Black
Bronze
Gold
Blue
Orange
Green



Plume | Black



Plume | Blue

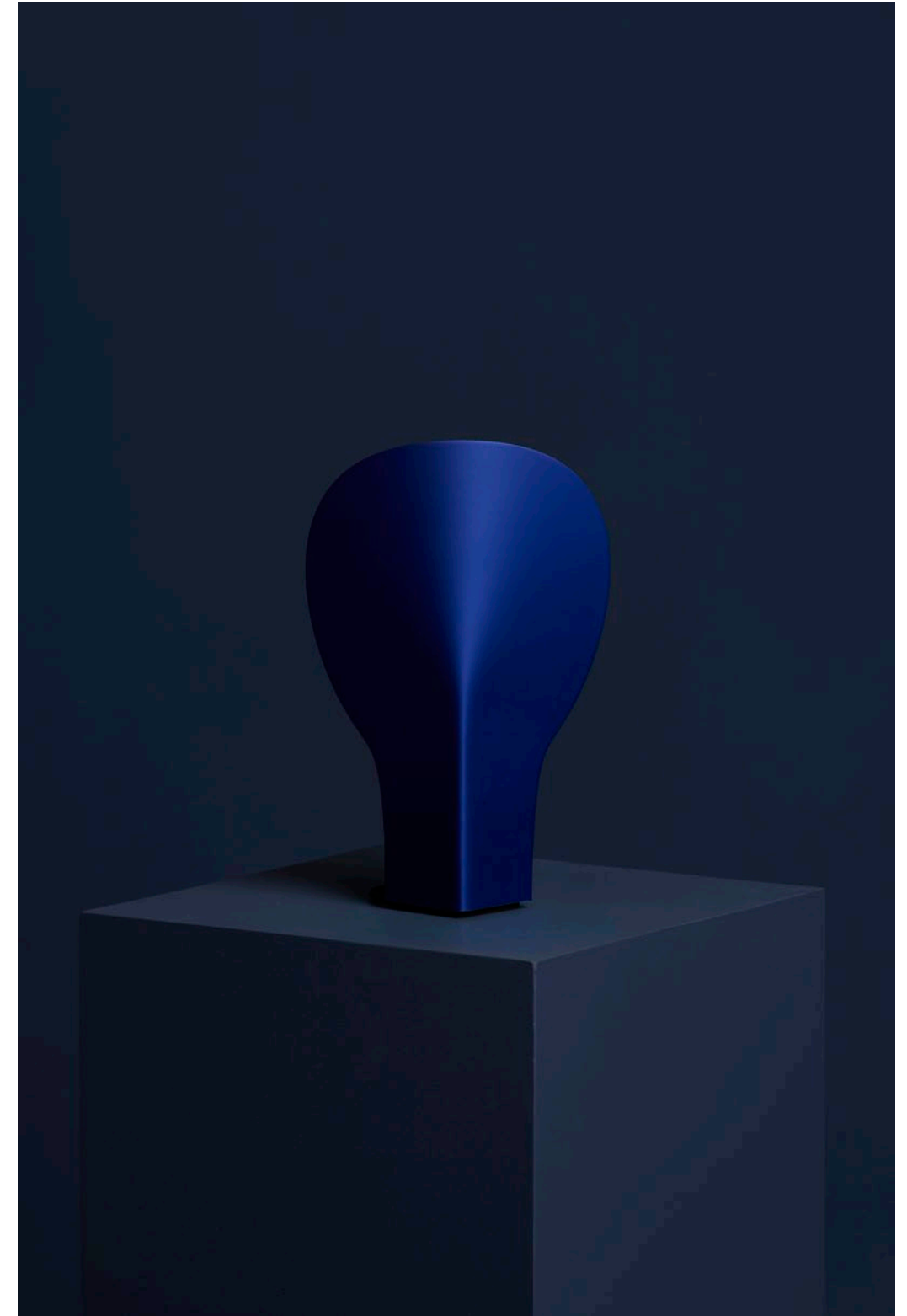



Design

Tom Fereday, 2022

Port is a celebration of the refractive properties of cast crystal glass through a unique table and wall light collection. Intricately crafted from solid crystal and hand finished brass, the sculptural glass monolith may be reversed within a slimline cradle to create two varied moods and light interactions.

Further showcasing the intriguing glass property of refraction, Port creates the illusion of a completely invisible lightsource, resulting in an abstract and captivating glow. Select from either a round or stadium profile, available in both wall and table lamp editions.



Model

Table round
Table stadium
Wall round
Wall stadium

Finish - Metalwork

Tumbled Brass
Black Powdercoat

WALL ROUND
WALL STADIUM

Ø190 X H70 MM
190 X 390 X H70 MM

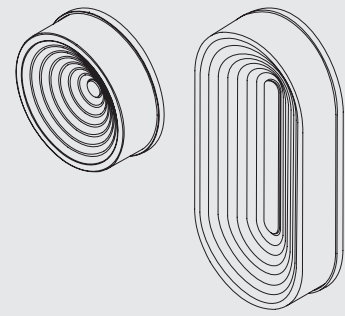
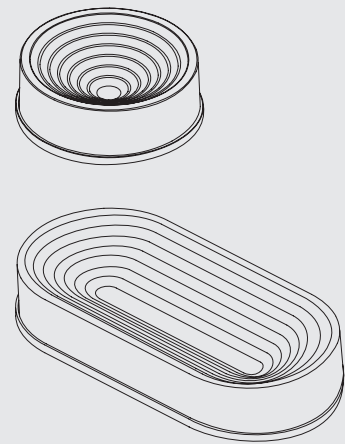

TABLE ROUND
TABLE STADIUM

Ø190 X H70 MM
190 X 390 X H70 MM



Port | Wall





Design

Anchor, 2016

Crafted by hand, Potter DS carries the mark of its maker: quintessentially tactile yet unexpectedly contemporary in form and line. Infused with the authentic and honest aesthetic of traditional ceramics, Potter DS challenges the typically rigid and industrial archetype of linear lighting with this warm and luxurious material.

A true hybrid of traditional clay working techniques and modern additive manufacturing technology, the ceramic outer floats around a high-performance LED core. The collection includes linear pendants and pared back wall lights, in a choice of glazes.



Model

Pendant
Wall

Dimensions

Pendant - Ø52 x L1800/2250 MM
Wall - Ø52 X 68 X H460 MM

Finish

Satin white
Charcoal



Potter DS Wall | Charcoal
Potter DS Wall | Satin White



Potter DS Pendant | Satin White





Design

Dan Treacy, 2016

A light of raw geometric intrigue. Pylite references the crystalline form of Pyrite minerals to conceive a light of intricate composition. Using a series of interlocking crystal prisms emitting light from seemingly invisible sources, this modular luminaire system puts the imagination in your hands.

Create cuboid and planar arrays of beautiful simplicity or spectacular complexity. From statement cuboid lamps to cloud-like formations as pendants, and breathtaking 'walls of light'. Pylite is available in powdercoated steel or solid brass in satin finish.



Model

Cube - Floor/Table lamp
Planar - Pendant/Wall

Dimension

Cube - 560 X 560 X H560 MM

Finish

Satin brass
Burnished copper powdercoat
Matte black powdercoat
Matte white powdercoat



Pylite Planar | Matte White Powdercoat



Pylite Cube | Satin Brass





Design

2016

Ramus - 'branching' in Latin - draws inspiration from dividing and linking structures found within the natural world. Each softly illuminated LED node smoothly transitions into arms of customisable length, extending in up to five different directions.

From minimalist planar arrangements through to epic three-dimensional constellations, Ramus' rare ability to link back upon itself arouses diverse narratives of a botanical, celestial and even molecular variety.



Dimensions

Module - Ø80 X H58 MM
Arms - Ø14 MM X customisable up to 2000 MM

Finish

Polished nickel
Satin black powdercoat
Satin white powdercoat
Bronze powdercoat
Custom powdercoat



Ramus | Bronze Powdercoat



Ramus | Bronze Powdercoat





Design

WOWOWA, 2015

Movement and flight, shadow and light. Rosella is an elegant abstraction of one of Australia's most recognisable bird species. Like its namesake, Rosella's geometric form is designed to shine, a flamboyant feature that can't help but take centre stage.

Designed to hang in a chandelier flock, or perfect in pairs, Rosella can be tailored with a range of powdercoat colours, or pare it back in a strictly sculptural white finish.



Dimensions

250 x 340 X H230 MM

Finish

White powdercoat
Custom



Design

2018, 2022

Saya: pared back luxury, indoor and outdoor.

Saya studies the similarities and differences between classic and contemporary design languages, refreshing archetypal domed lighting forms with uncompromisingly refined detailing. Two precisely sized pendant offerings and two subtly different wall forms unite a low profile silhouette with luxurious tumbled brass hardware and integrated LED technology.

Saya brings refined beauty and minimalism to hospitality venues, residential and commercial settings alike. All Saya models are weather sealed, bringing elegant lighting to both interior and exterior dining and entertaining spaces.



Model

Pendant
Wall

Finish

Black & tumbled brass
White & tumbled brass
Custom & tumbled brass

Saya Pendant 800 | Black & Tumbled Brass



Saya Wall South | Black & Tumbled Brass
Saya Wall North | Black & Tumbled Brass



PENDANT 400

Ø420 X H115 MM

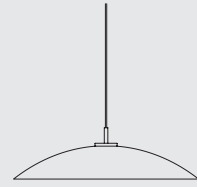

PENDANT 800

Ø800 X H185 MM

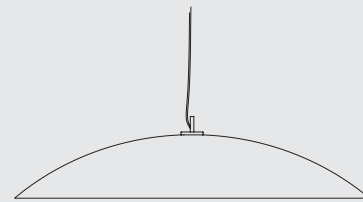

WALL NORTH

716 X 420 X H202 MM

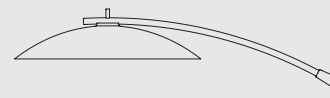

WALL SOUTH

714 X 420 X H204 MM

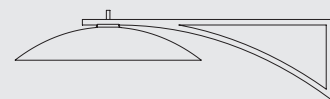

Saya Model

Saya Pendant 800 | Black & Tumbled Brass





 Design

2013

Distinction through proportion and material. The minimalist design of Scope brings character to the essential cylindrical form, adding depth and dimension through a deeply glowing expressed diffuser or sculpted anodised reflector.

Available in pendant, surface mount and wall options, Scope can be scaled up and down - reaching impressive lengths of up to 6 metres or down to 120 millimetres. Finished in customisable powdercoat colours.



Model

Pendant
Wall

Dimensions

Ø60 X H165/255/365/605/CUSTOM MM
Ø100 X H165/255/365/605/CUSTOM MM

Finish

Asteroid powdercoat
Corten powdercoat
Snow powdercoat



Scope Pendant | Asteroid
 <

Scope Pendant | Snow
 Scope Wall | Custom Textured Black Powdercoat
 v





Design

Jon Goulder, 2018

Defined by crisp lines and monumental form, the Standley collection of outdoor lighting draws on iconic Australian architecture and the rugged beauty of the Australian landscape. With raw finishes, natural stone materiality, and the creative freedom of custom colours and façades, Standley is as diverse as the landscape around it.

Emphasising attention to materials, Standley illuminates itself as well as its surrounds, grazing subtle light down the fitting's feature facades. Standley is available both wall mounted and in bollard form.



Model	Wall Bollard	
Dimension	Wall - 140 X 93 X H315 MM Bollard - 180 X 180 X H1010 MM	
Finish - Metalwork	Black powdercoat White powdercoat Corten powdercoat	
Finish - Facade	Bluestone Carrara marble	Matching powdercoat Custom

Standley Wall | White Powdercoat & Carrara Marble



Standley Wall | Black Powdercoat & Bluestone





Design

2015

Gently curved petals conjure the inimitable tulip. The soft, sculptural form of Tulip carefully preserves a lightness of form, while delivering superior LED illumination.

Made from acoustic panel, Tulip combines decorative flair with acoustic benefits for both commercial and residential environments. Select from a range of colours.



Dimensions

Ø700 X H400 MM

Finish

Ash	Oxford
Calypso	Pearl
Charcoal	Pistachio
Mandarin	Saffron
Mantis	Valencia
Onyx	Vista



Design

Studio Truly Truly, 2018

A collection inspired by typographic characters, CILON harnesses the purity of cylindrical form and a unique modularity to establish a new lighting aesthetic. CILON's seven lighting fixtures - or characters - can be cleverly arranged to create a compelling language of expression.

Using Rakumba's Typography rail system, each light can be positioned anywhere on and around the rail to create a unique sculpture. Lights can be controlled independently of one another for a highly tailored lighting effect. Browse Rakumba's curated suite of compositions, or create your own.

CILON is the first stand-alone collection in the Typography Series by Studio Truly Truly and Rakumba. Through its design and composition, Typography establishes a new language in decorative lighting.



Model

Rail configuration
Wall

Finish

Black anodised
Golden anodised
Bronze anodised

Luminaire

Spot
Roll
Staff
Layer
Mini
Rib
Disc



Rib Sconce | Golden Anodised

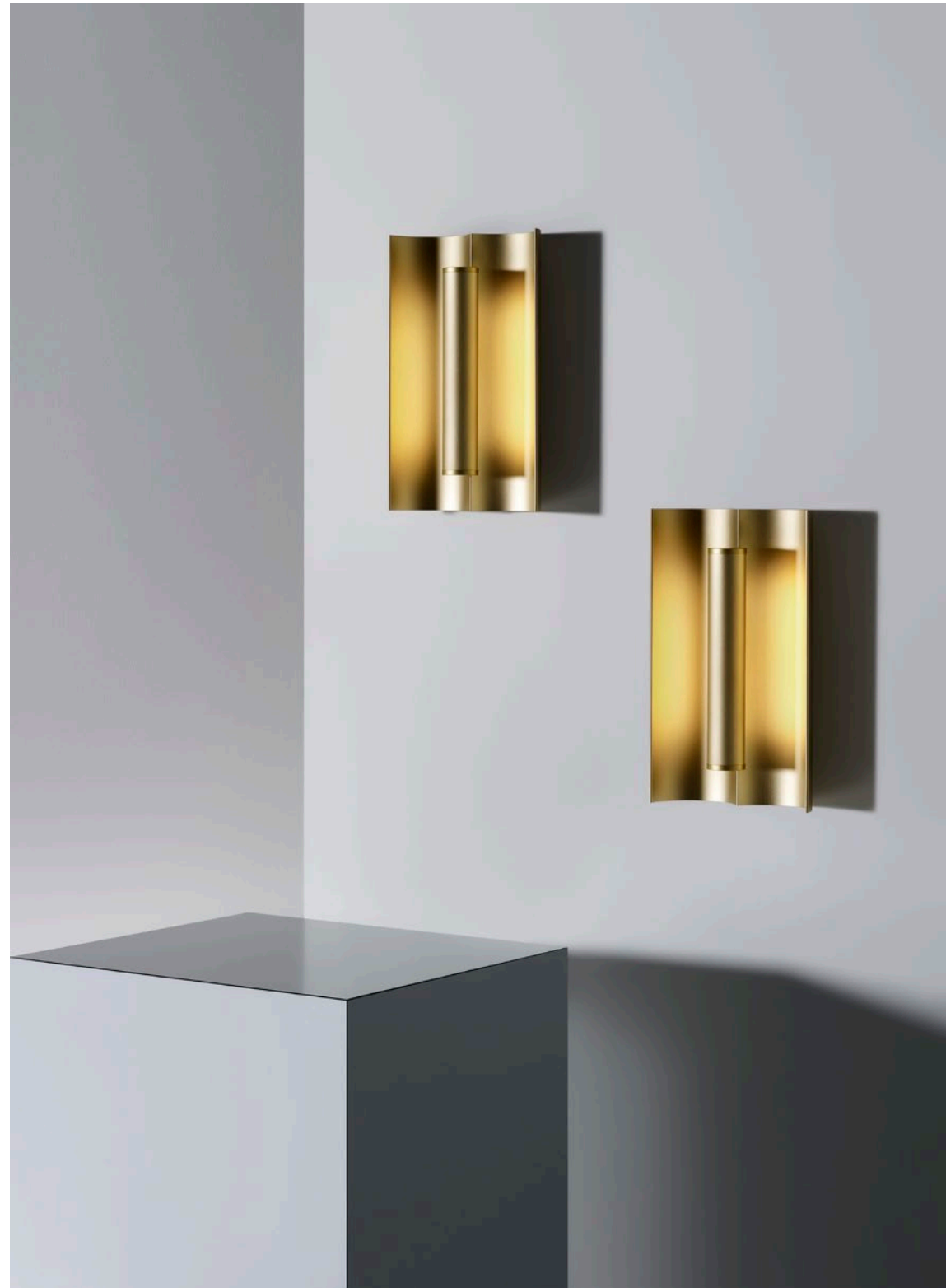

Disc & Mini Gantry | Composition B





Roll & Mini Gantry Chandelier | Black Anodised

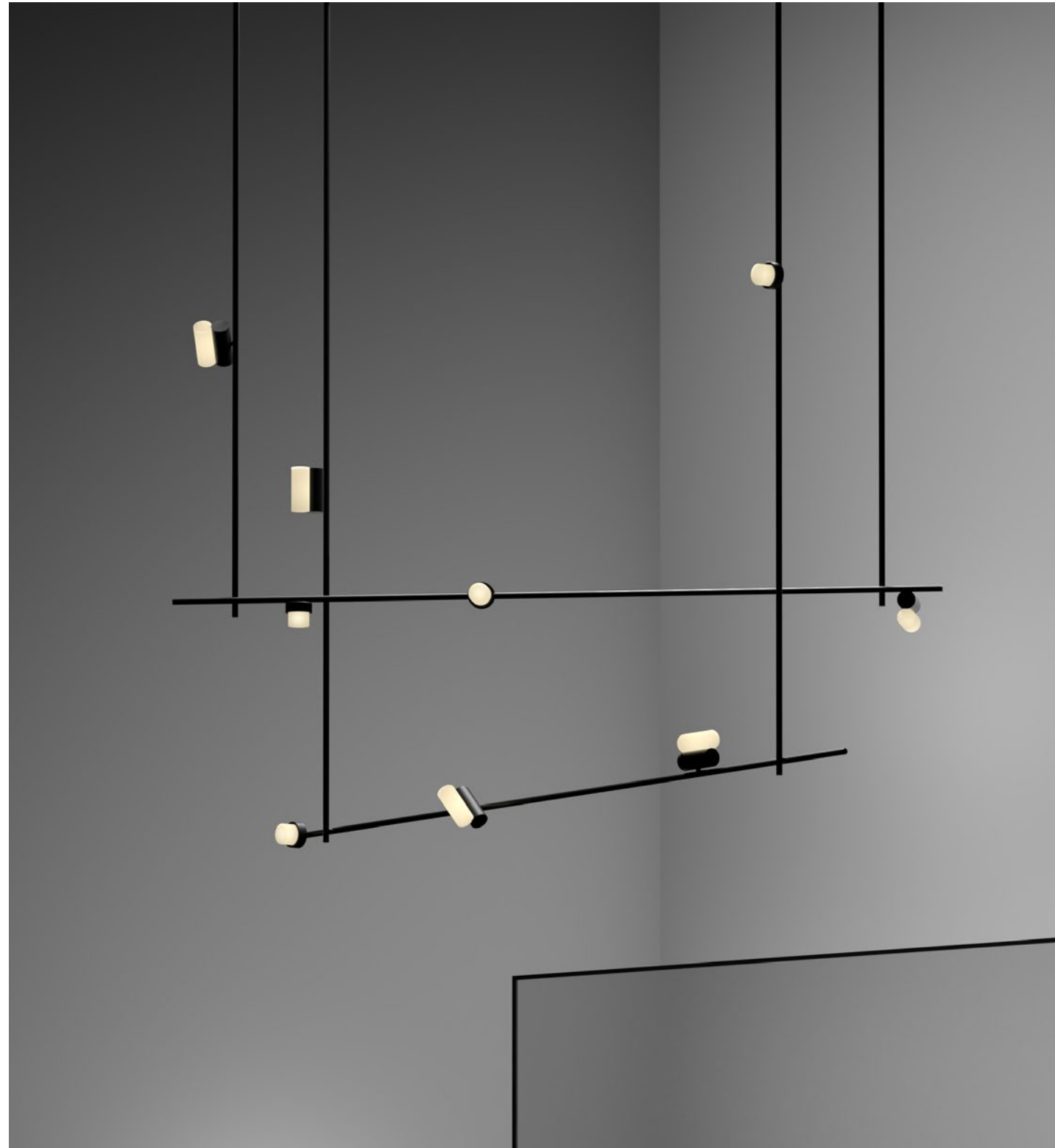

Layer Pendant | Black Anodised



Staff Sconce | Golden Anodised
Staff Pendant | Golden Anodised

Rib Chandelier | Golden Anodised
>



SPOT 60 X 140 X H290 MM

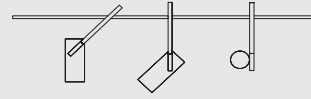

ROLL 60 X 120 X H145 MM

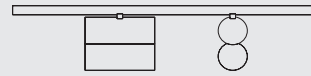

STAFF Ø90 X H410 MM

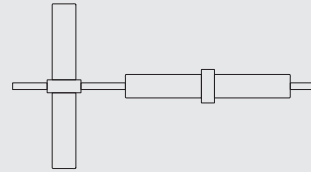

LAYER Ø90 X H80 MM

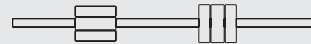

MINI Ø90 X H75 MM

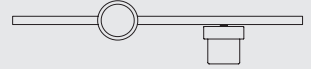

RIB 60 X 165 X H270 MM

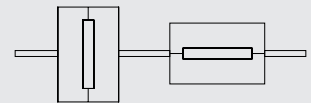

DISC Ø170 X 75 X H260 MM

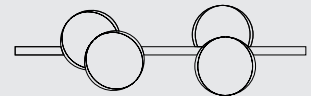

STAFF SCONCE 90 X 102 X H410 MM
 STAFF WALL XXL Ø420 X D97 MM
 STAFF WALL XXL STACK Ø420 X D132 MM

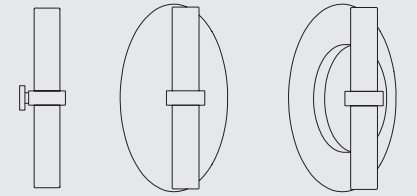

LAYER SCONCE 90 X 102 X H80 MM
 LAYER WALL MEDIUM Ø300 X D97 MM
 LAYER WALL MEDIUM STACK Ø300 X D132 MM

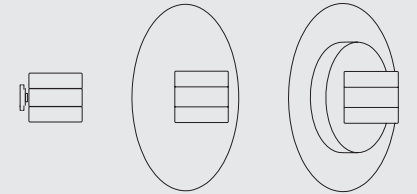

MINI SCONCE 90 X 90 X H75 MM
 MINI WALL MEDIUM Ø300 X D82 MM
 MINI WALL MEDIUM DOUBLE STACK Ø300 X D148 MM

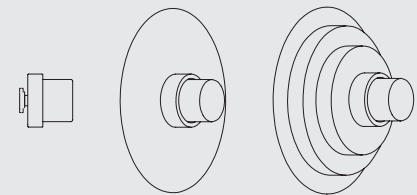

RIB SCONCE 165 X 72 X H270 MM

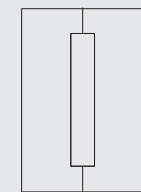



Design

Studio Truly Truly, 2021

Sculpture suspended in space, the VELA collection tells a story with its planetary spheres and eclipse evoking discs. Named for the Vela constellation, spherically formed luminaires use the Rakumba Typography rail system as the axis of an orbital space. Distinctive discs can both frame or obscure the decorative arrangement of spheres, creating an interplay of light and shadow.

The seven unique fittings within the collection can be positioned anywhere along or around the Typography rails. In turn, the rails can be combined in vertical or horizontal orientations; creating pieces of quiet simplicity, or incredible grandeur. Select from Rakumba's curated suite of compositions, or create your own unique sculpture.

VELA is the second stand-alone collection in the Typography Series by Studio Truly Truly and Rakumba. Through authentic design and composition, Typography establishes a new language in decorative lighting.



Model

Rail configuration
Wall

Finish

Black anodised
Golden anodised

Luminaire

Globe 60	Eclipse 75
Globe 85	Eclipse 110
Globe 110	Eclipse 150
Amid	



Typography Vela | Wall Sconce



Typography Vela | Pendant C



Typography Vela | Pendant E



▼ Typography Vela | Gantry



▼ Typography Vela | Gantry A
Typography Vela | Globe 110, Globe 85



Typography Vela | Globe 60 Plate Sconce
v

Typography Vela | Pendant A
>



GLOBE 60 Ø60 X H85 MM

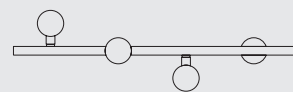

GLOBE 85 Ø85 X H110 MM

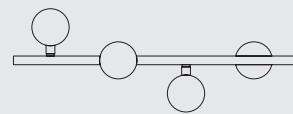

GLOBE 110 Ø110 X H140 MM

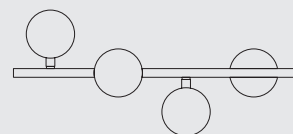

AMID Ø75 X H85 MM

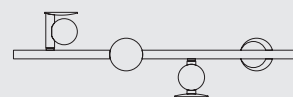

ECLIPSE 75 Ø75 X H450 MM

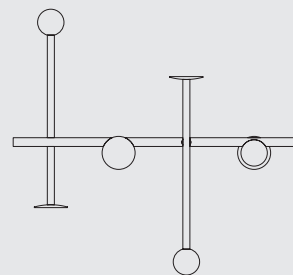

ECLIPSE 110 Ø110 X H205 MM

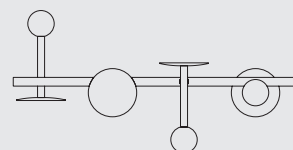

ECLIPSE 150 Ø150 X H250 MM

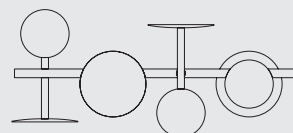

GLOBE 60 SCONCE Ø60 X D83 MM
GLOBE 60 PLATE SCONCE Ø75 X D83 MM

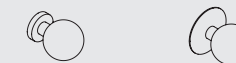

GLOBE 85 SCONCE Ø85 X D108 MM
GLOBE 85 PLATE SCONCE Ø110 X D108 MM



GLOBE 110 SCONCE Ø110 X D134 MM
GLOBE 110 PLATE SCONCE Ø150 X D134 MM



AMID SCONCE Ø75 X H95 MM



ECLIPSE 75 SCONCE 98 X 75 X H450 MM

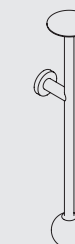

ECLIPSE 110 SCONCE 116 X 110 X H205 MM





Design

Sebastian Herkner, 2023

Evoking scrolled natural forms - from botanical to nautical - designer Sebastian Herkner draws on Rakumba's heritage of textile lampshade craftsmanship to create the Volute collection.

Herkner challenges skills honed over time with new lampshade geometries previously considered near impossible. Leveraging Rakumba's design ethos of "effortless complexity", Volute pushes craft to its limits, delivering distinguished contemporary presence with the softness of fabric.

With two shells of richly textured customisable fabrics embracing a warm glowing light, Volute is available in pendant, wall, table and floor editions.



Model

Pendant
Wall
Table lamp
Floor lamp

Finish

Putty
Linen
Graphite
Dice
Flax
Custom

FLOOR 1400

Ø650 X H1400 MM

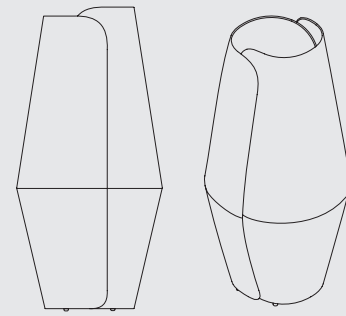

FLOOR 900

Ø650 X H940 MM

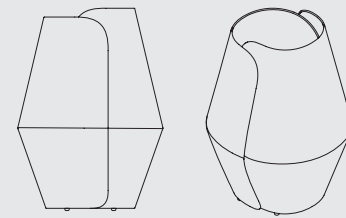
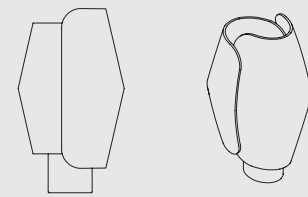

TABLE LAMP

Ø300 X H520 MM



PENDANT

Ø300 X H450 MM

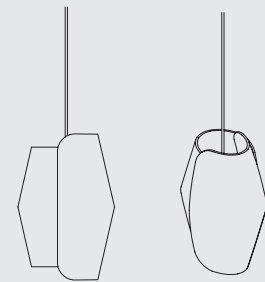

Volute | Pendant and Table Lamp

Volute | Floor Lamp

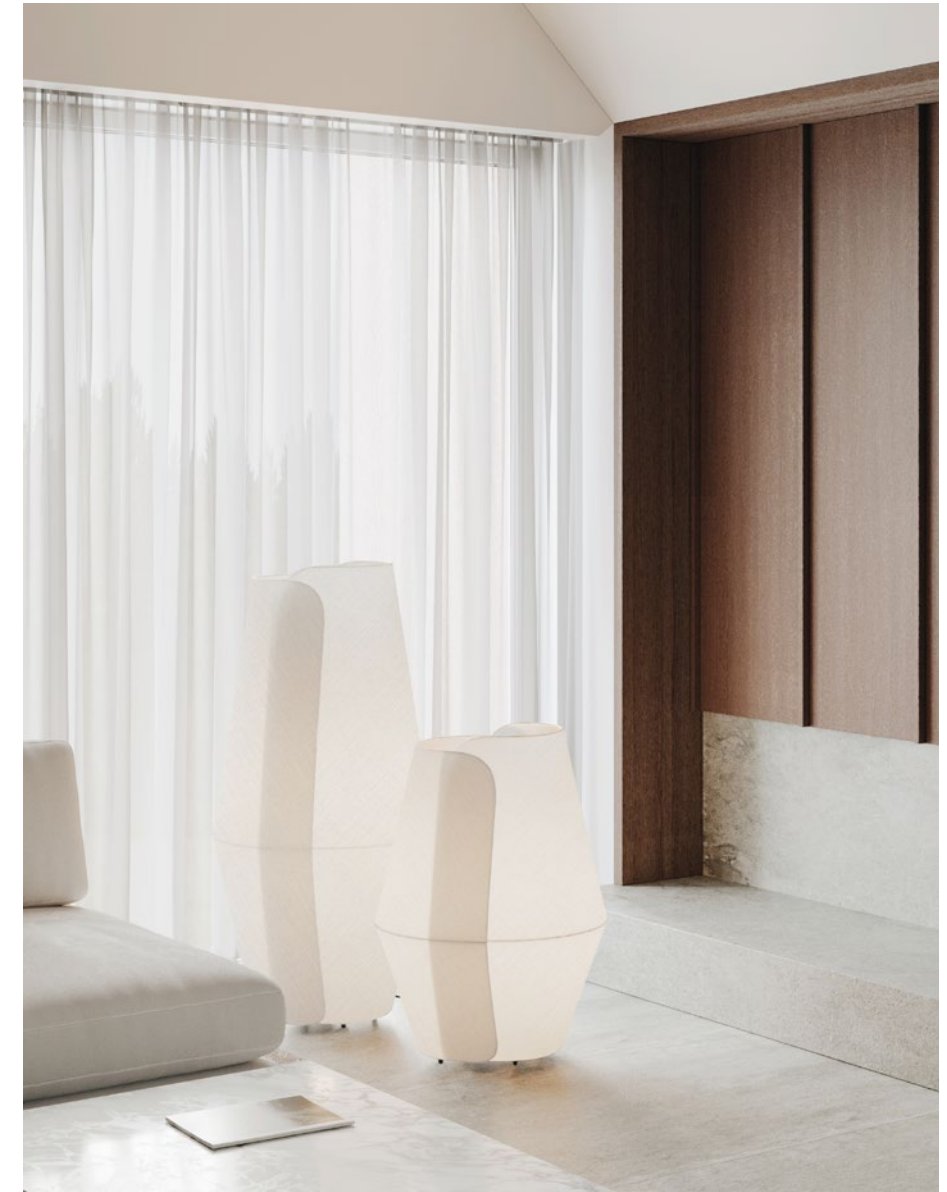

ALL RIGHTS RESERVED © RAKUMBA, 2023
Contact marketing@rakumba.com for high resolution
images and individual image credits

PHOTOGRAPHY/IMAGE CREDITS

Rodrigo Rabaco
Haydn Cattach
AFTR Studio
Ben Hosking
Adam Gibson
Tom Blachford
Tom Ferguson
Kate Shanasy
Sean Fennessy
Derek Swalwell
Nicole Reed
Alexis Christodoulou
Fiona Susanto
Timothy Kaye
Tom Skeeahan
Pim Top

WWW.RAKUMBA.COM
SALES@RAKUMBA.COM
ALL RIGHTS RESERVED © RAKUMBA, 2023

Rakumba